

MPL series

Pedestrian ergonomic lift pallet truck

2,000kg

- Replenishment dedicated shelf stacker to reduce operator's back fatigue
- Ergonomic tiller head and low mounted tiller arm offer excellent operator comfort
- Compact powerhead length and creep speed for excellent manoeuvrability
- AC drive motor and MOSFET transistor control on traction and hydraulics
- On-board charger option
- CANbus technology



Truck Dimensions

$$Ast = Wa + (l_6 - x) + a$$

$$a = 200\text{mm}$$

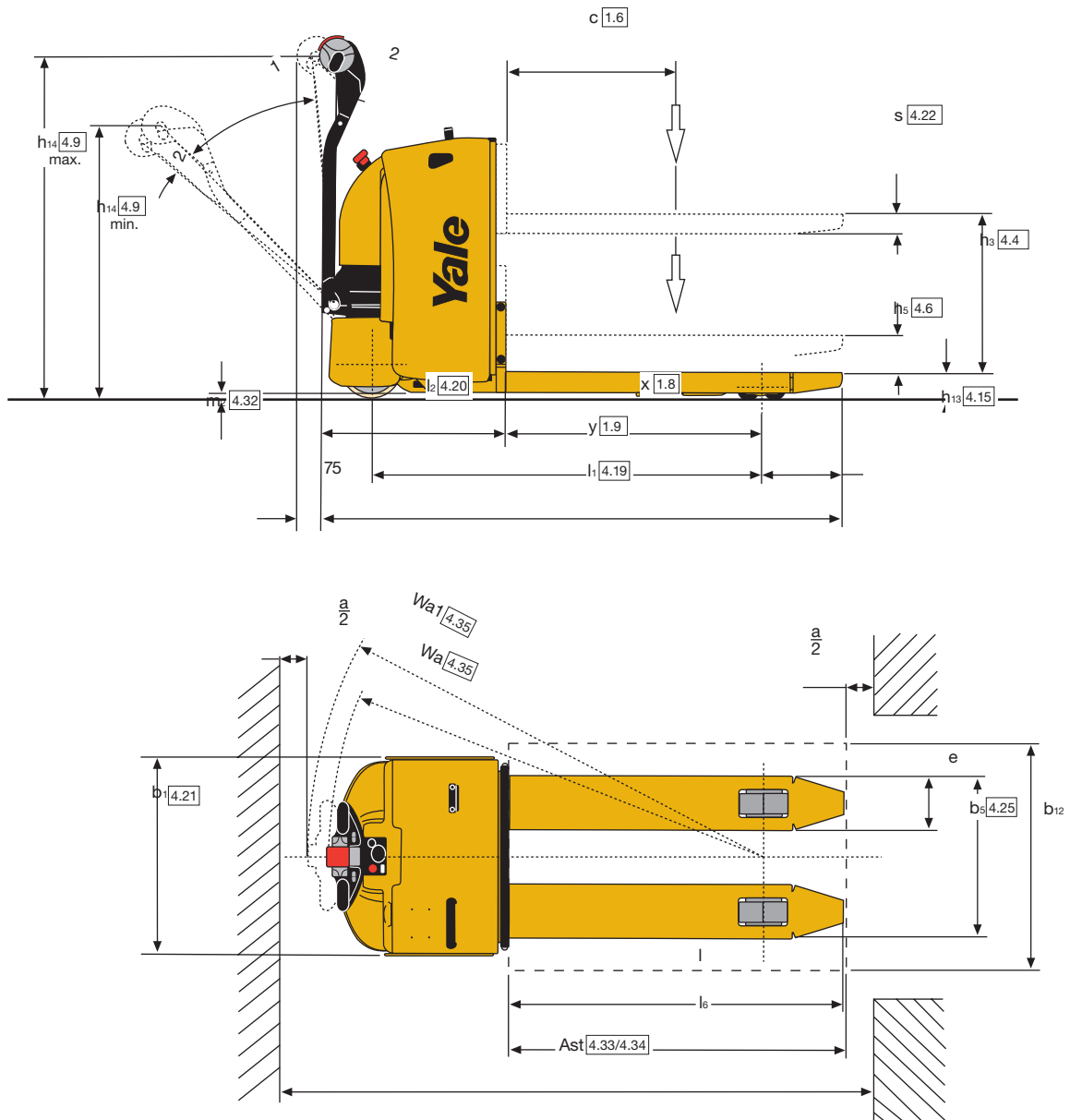

Tiller Head

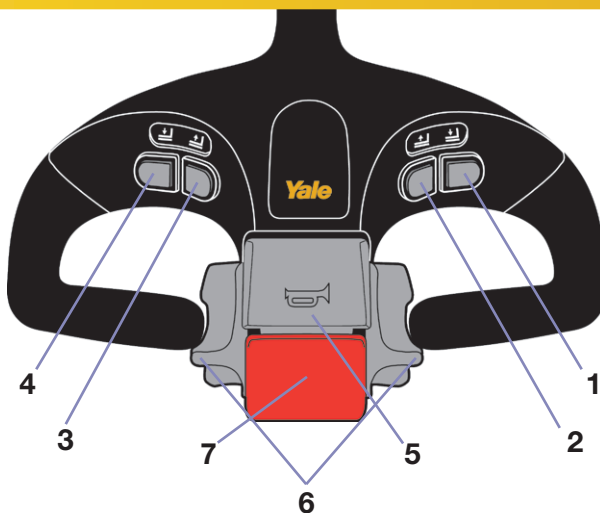

- 1 Fork lowering
- 2 Fork lifting
- 3 Lift frame
- 4 Lower frame
- 5 Horn
- 6 Forward/reverse control speed
- 7 Reverse gear button

VDI 2198 – General Specifications

Distinguishing mark	1.1	Manufacturer (abbreviation)		Yale
	1.2	Manufacturer's type designation		MP20DL
	1.3	Drive: electric (battery or mains), diesel, petrol, fuel gas		Electric (battery)
	1.4	Operator type: hand, pedestrian, standing, seated, order-picker		Pedestrian
	1.5	Rated capacity/Rated load	Q (t)	2.0
		Capacity, load (on the forks)	Q (t)	0.7
		Capacity, load (on the frame)	Q (t)	2.0
	1.6	Load centre distance	c (mm)	600
	1.8	Load distance, centre of drive axle to fork ⁽¹⁾	x (mm)	906
1.9	Wheelbase ⁽¹⁾	y (mm)	1380	
Weights	2.1	Service weight ⁽⁴⁾	kg	615
	2.2	Axle loading, laden front/rear ⁽²⁾	kg	780 / 1835
	2.3	Axle loading, unladen front/rear	kg	440 / 175
Tyres/chassis	3.1	Tyres: polyurethane, tophane, vulkollan, front/rear		Polyurethane / Vulkollan
	3.2	Tyre size, front	ø (mm x mm)	230 x 75
	3.3	Tyre size, rear	ø (mm x mm)	85 x 74
	3.4	Additional wheels (dimensions)	ø (mm x mm)	100 x 40
	3.5	Wheels, number front/rear (x = driven wheels)		1x + 2/4
	3.6	Tread, front	b10 (mm)	458
	3.7	Tread, rear	b11 (mm)	377
Dimensions	4.4	Lift	h3 (mm)	560
	4.6	Initial lift	h5 (mm)	130
	4.9	Height drawbar in driving position min./max. ⁽²⁾	h14 (mm)	735 / 1200
	4.15	Height, lowered	h13 (mm)	92
	4.19	Overall length	l1 (mm)	1843
	4.20	Length to face of forks	l2 (mm)	651
	4.21	Overall width	b1 / b2 (mm)	700
	4.22	Fork dimensions DIN ISO 2331	s/e/l (mm)	70 / 190 / 1190
	4.25	Distance between fork-arms	b5 (mm)	570
	4.32	Ground clearance, centre of wheelbase	m2 (mm)	20
	4.34.1	Aisle width for pallets 1000mm x 1200mm crossways	Ast (mm)	2044
4.34.2	Aisle width for pallets 800mm x 1200mm lengthways	Ast (mm)	2054	
4.35	Turning radius ⁽¹⁾	Wa (mm)	1560	
Performance data	5.1	Travel speed, laden/unladen	km/h	6.0 / 6.0
	5.1.1	Travel speed, laden/unladen, backwards	km/h	-
	5.2	Lift speed, laden/unladen ⁽³⁾	m/s	0.09 / 0.10
	5.3	Lowering speed, laden/unladen ⁽³⁾	m/s	0.17 / 0.15
	5.7	Gradeability, laden/unladen	%	-
	5.8	Max. gradeability, laden/unladen	%	8/20
5.10	Service brake		Electromagnetic	
Electric engine	6.1	Drive motor S2 60 minute rating	kW	1.2
	6.2	Lift motor, S3 15% rating	kW	1.4
	6.3	Battery according to DIN 43531/35/36 A,B,C, no		no
	6.4	Battery voltage/nominal capacity K5	(V)/(Ah)	24 / 200
	6.5	Battery weight ⁽⁴⁾	kg	185
	6.6	Energy consumption according to VDI cycle	kWh/h at number of cycles	0.44
8.1	Type of drive unit		Mosfet AC	
10.7	Sound pressure level at the driver's seat	dB (A)	< 70	

⁽¹⁾ With load section lifted: -85mm

⁽²⁾ Tiller arm in vertical working position (creep speed)

⁽³⁾ h3 lift

⁽⁴⁾ These values may vary of +/- 5%

All values are nominal values and they are subject to tolerances.

For further information, please contact the manufacturer.

Yale products might be subject to change without notice.

Lift trucks illustrated may feature optional equipment.

Values may vary with alternative configurations.

MPL Series

Models: MP20DL



Description

The MP20DL is a powerful pedestrian pallet truck with a low lift mast designed to eliminate back-stress associated with replenishment /order picking and light stacking applications.

It's narrow and short chassis make-it both manoeuvrable and compact.

The creep speed button feature makes it fully manoeuvrable even with the tiller in the upright position.

The optional on board charger makes charging at mains socket outlets easy and convenient.

Designed for the most difficult application conditions for example driving on ramps, working in tight spaces or loading and unloading lorries.

The mini-mast allows the support arms and load to be lifted to a height of 780 mm allowing the picking and replenishment or positioning at a 'user friendly' height.

Light stacking tasks including the handling of half or full euro-pallets can be easily undertaken with the separate support arm and mast lift. This allows the retrieving or placing of a load into a van or on to an elevated support table.

The capacity of the load arm lift is 2,000kg and the mini-mast forklifts 700kg.

The powerful maintenance-free AC drive motor provides high speed and powerful acceleration with low energy consumption making the MP20DL ideal for fast, efficient goods throughput.

The operator is in control at all times with the long, low mounted and low resistance tiller for steering. It ensures an essential safe distance is maintained between the operator and truck. The tiller arm has been specially designed to ensure the truck never gets "too close" to the operator in tight spaces or corners. If space is particularly confined, the creep speed button permits safe travel with the tiller in the upright position. Depressing the creep speed button releases the brake allowing the truck to travel at a reduced speed.

When the tiller is released a gas spring automatically returns to the vertical position, this ensures a controlled stop and activation of the truck brake.

Tiller

The controls on tiller head have been ergonomically designed for right or left hand operators.

The push buttons for horn, lifting and lowering can be operated without changing the grip, reducing operator fatigue.

For operators wearing gloves the large sized buttons have depressed areas for ease of operation.

The tiller head layout permits the simultaneous use of the hoisting, lowering and driving controls.

The hand guard and the rounded frame provide increased security for the operator's hands on the tiller.

The large abdomen impact switch in the tiller head prevents the truck from trapping the operator even when the tiller is an almost vertical position. The truck automatically switches from forward to backward travel when the abdomen switch touches the operator's body.

The internal components (sensors and tiller PCB) are in housed in IP 65 enclosures. All plug connectors and cable harnesses are manufactured to IP 54, making them less susceptible to environmental factors for instance rain and dust.

The tiller head is manufactured from a reinforced body and a steel tiller arm.

Innovative AC technology

The AC motor provides increased efficiency with reduced operating costs over the entire lifespan of the truck and has the following advantages:

- High efficiency with excellent energy management
- Powerful acceleration
- Step-less regulation of travel speed using the butterfly direction selector switch
- Quick direction change with no "waiting" time
- Maintenance free drive motor (no carbon brushes)
- 2-year/4000 hours warranty
- High travel comfort with easily and individually adjustable performance parameters (set by service engineer) to provide the greatest productivity in particular applications

Operation Features

- Adjustable speed control which facilitates comfortable operation.
- Travel speed is managed by the butterfly direction controls and is kept constant in all travel situations including the negotiation of gradients.

- Automatic braking prevents unintentional roll-back when operating on ramps.
- Low noise levels during travelling.
- Standard braking is achieved by releasing the drive switch or by plugging (reversing the direction of travel).
- The AC motor acts as a brake and consumes no energy from the battery.
- A laptop connector is provided underneath the battery cover for ease of access.

Braking system

The braking system is made with independent systems.

Standard operating brake:

- drive motor braking - activated by releasing the butterfly switch or reverse travel direction braking (plugging)
- electromagnetic braking - achieved by an electromagnetic brake which is protected against the ingress of contaminants. It acts as emergency brake when the tiller is fully lowered or in the full vertical position or when the emergency button is applied
- parking brake - is automatically applied when the tiller is in the full vertical position

Support rollers for optimised cornering

Sprung cushioned support wheels absorb unstable forces that can be experienced in certain applications.

The truck has robust support rollers with shock absorbers that can be easily and quickly adjusted. This makes the truck ideal when operating in arduous applications for instance ramp and gradient locations.

High productivity and low energy consumption

The energy efficient AC technology used in the MP20DL in combination with battery capacities of up to 200Ah ensure continued operation in applications with long shift times.

The optional on board battery charger for the 200 Ah BS battery provides easy charging at any mains socket outlet.

Options

- On board battery charger
- Single load roller (reduces capacity to 1500kg)
- Load backrest (height above fork face 1000 mm)
- Cover for mast area
- Cold store -30°C
- Traction wheels manufactured from various compounds
- 200Ah "Airmix" and "Autofil" batteries

NACCO Materials Handling Limited
trading as **Yale Europe Materials Handling**
Centennial House, Frimley Business Park,
Frimley, Surrey GU16 7SG, United Kingdom.

Tel: +44 (0) 1276 538500 Fax: +44 (0) 1276 538559

www.yale-forklifts.eu

Country of Registration: England. Company Registration Number: 02636775



Safety. This truck conforms to the current EU requirements. Specification is subject to change without notice.

Yale, VERACITOR and  are registered trademarks. "PEOPLE, PRODUCTS, PRODUCTIVITY", PREMIER, Hi-Vis, and CSS are trademarks in the United States and certain other jurisdictions. MATERIALS HANDLING CENTRAL and MATERIAL HANDLING CENTRAL are Service Marks in the United States and certain other jurisdictions.  is a Registered Copyright. © Yale Europe Materials Handling 2014. All rights reserved.

Truck shown with optional equipment

Printed in The United Kingdom (0914HG) EN
Publication part no. 258985406 Rev.03